

KVR667D2D8F5K2/4G

4GB (2GB 256M x 72-Bit x 2 pcs.) PC2-5300

CL5 ECC 240-Pin FBDIMM Kit

DESCRIPTION

ValueRAM's KVR667D2D8F5K2/4G is a kit of two 2GB (256M x 72-bit) PC2-5300 CL5 SDRAM (Synchronous DRAM) "fully buffered" ECC "dual rank" memory modules. Total kit capacity is 4GB (4096MB). Each module is based on eighteen 128M x 8-bit 667MHz DDR2 FBGA components. Each module also includes an AMB device (Advanced Memory Buffer). The electrical and mechanical specifications are as follows:

SPECIFICATIONS

· FBDIMM Module	240-pin
· JEDEC Standard	R/C B
· Memory Organization	2 rank of x8 devices
· DDR2 DRAM Interface	SSTL_18
· DDR2 Speed Grade	667 Mbps
· CAS Latency	5-5-5
· Module Bandwidth	5.3 GB/s
· DRAM	VDD = VDDQ = 1.8V
· AMB	VCC = VCCFBD = 1.5V
· EEPROM	VDDSPD = 3.3V (typical)
· Heat Spreader	Full DIMM Heat Spreader (FDHS)
· PCB Height	30.35mm, double-side
· RoHS Compliant	

Continued >>

DDR2 240-pin FBDIMM Pinout:

Pin #	Front Side	Pin #	Back Side	Pin #	Front Side	Pin #	Back Side	Pin #	Front Side	Pin #	Back Side	Pin #	Front Side	Pin #	Back Side
1	V _{DD}	121	V _{DD}	31	PN3	151	SN3	61	PN9	181	SN9	91	PS9	211	SS9
2	V _{DD}	122	V _{DD}	32	PN3	152	SN3	62	V _{SS}	182	V _{SS}	92	V _{SS}	212	V _{SS}
3	V _{DD}	123	V _{DD}	33	V _{SS}	153	V _{SS}	63	PN10	183	SN10	93	PS5	213	SS5
4	V _{SS}	124	V _{SS}	34	PN4	154	SN4	64	PN10	184	SN10	94	PS5	214	SS5
5	V _{DD}	125	V _{DD}	35	PN4	155	SN4	65	V _{SS}	185	V _{SS}	95	V _{SS}	215	V _{SS}
6	V _{DD}	126	V _{DD}	36	V _{SS}	156	V _{SS}	66	PN11	186	SN11	96	PS6	216	SS6
7	V _{DD}	127	V _{DD}	37	PN5	157	SN5	67	PN11	187	SN11	97	PS6	217	SS6
8	V _{SS}	128	V _{SS}	38	PN5	158	SN5	68	V _{SS}	188	V _{SS}	98	V _{SS}	218	V _{SS}
9	V _{CC}	129	V _{CC}	39	V _{SS}	159	V _{SS}	KEY				99	PS7	219	SS7
10	V _{CC}	130	V _{CC}	40	PN13	160	SN13	69	V _{SS}	189	V _{SS}	100	PS7	220	SS7
11	V _{SS}	131	V _{SS}	41	PN13	161	SN13	70	PS0	190	SS0	101	V _{SS}	221	V _{SS}
12	V _{CC}	132	V _{CC}	42	V _{SS}	162	V _{SS}	71	PS0	191	SS0	102	PS8	222	SS8
13	V _{CC}	133	V _{CC}	43	V _{SS}	163	V _{SS}	72	V _{SS}	192	V _{SS}	103	PS8	223	SS8
14	V _{SS}	134	V _{SS}	44	RFU*	164	RFU*	73	PS1	193	SS1	104	V _{SS}	224	V _{SS}
15	V _{TT}	135	V _{TT}	45	RFU*	165	RFU*	74	PS1	194	SS1	105	RFU**	225	RFU**
16	VID1	136	VID0	46	V _{SS}	166	V _{SS}	75	V _{SS}	195	V _{SS}	106	RFU**	226	RFU**
17	RESET	137	DNU/M_Test	47	V _{SS}	167	V _{SS}	76	PS2	196	SS2	107	V _{SS}	227	V _{SS}
18	V _{SS}	138	V _{SS}	48	PN12	168	SN12	77	PS2	197	SS2	108	V _{DD}	228	SCK
19	RFU**	139	RFU**	49	PN12	169	SN12	78	V _{SS}	198	V _{SS}	109	V _{DD}	229	SCK
20	RFU**	140	RFU**	50	V _{SS}	170	V _{SS}	79	PS3	199	SS3	110	V _{SS}	230	V _{SS}
21	V _{SS}	141	V _{SS}	51	PN6	171	SN6	80	PS3	200	SS3	111	V _{DD}	231	V _{DD}
22	PN0	142	SN0	52	PN6	172	SN6	81	V _{SS}	201	V _{SS}	112	V _{DD}	232	V _{DD}
23	PN0	143	SN0	53	V _{SS}	173	V _{SS}	82	PS4	202	SS4	113	V _{DD}	233	V _{DD}
24	V _{SS}	144	V _{SS}	54	PN7	174	SN7	83	PS4	203	SS4	114	V _{SS}	234	V _{SS}
25	PN1	145	SN1	55	PN7	175	SN7	84	V _{SS}	204	V _{SS}	115	V _{DD}	235	V _{DD}
26	PN1	146	SN1	56	V _{SS}	176	V _{SS}	85	V _{SS}	205	V _{SS}	116	V _{DD}	236	V _{DD}
27	V _{SS}	147	V _{SS}	57	PN8	177	SN8	86	RFU*	206	RFU*	117	V _{TT}	237	V _{TT}
28	PN2	148	SN2	58	PN8	178	SN8	87	RFU*	207	RFU*	118	SA2	238	VDDSPD
29	PN2	149	SN2	59	V _{SS}	179	V _{SS}	88	V _{SS}	208	V _{SS}	119	SDA	239	SA0
30	V _{SS}	150	V _{SS}	60	PN9	180	SN9	89	V _{SS}	209	V _{SS}	120	SCL	240	SA1
								90	PS9	210	SS9				

RFU = Reserved Future Use.

* These pin positions are reserved for forwarded clocks to be used in future module implementations

** These pin positions are reserved for future architecture flexibility

1) The following signals are CRC bits and thus appear out of the normal sequence: PN12/PN12, SN12/SN12, PN13/PN13, SN13/SN13, PS9/PS9, SS9/SS9

Continued >>

DIMM Connector Pin Description:

Pin Name	Pin Description	Count
SCK	System Clock Input, positive line ¹	1
$\overline{\text{SCK}}$	System Clock Input, negative line ¹	1
PN[13:0]	Primary Northbound Data, positive lines	14
$\overline{\text{PN}}[13:0]$	Primary Northbound Data, negative lines	14
PS[9:0]	Primary Southbound Data, positive lines	10
$\overline{\text{PS}}[9:0]$	Primary Southbound Data, negative lines	10
SN[13:0]	Secondary Northbound Data, positive lines	14
$\overline{\text{SN}}[13:0]$	Secondary Northbound Data, negative lines	14
SS[9:0]	Secondary Southbound Data, positive lines	10
$\overline{\text{SS}}[9:0]$	Secondary Southbound Data, negative lines	10
SCL	Serial Presence Detect (SPD) Clock Input	1
SDA	SPD Data Input / Output	1
SA[2:0]	SPD Address Inputs, also used to select the DIMM number in the AMB	3
VID[1:0]	Voltage ID: These pins must be unconnected for DDR2-based Fully Buffered DIMMs VID[0] is V_{DD} value: OPEN = 1.8 V, GND = 1.5 V; VID[1] is V_{CC} value: OPEN = 1.5 V, GND = 1.2 V	2
$\overline{\text{RESET}}$	AMB reset signal	1
RFU	Reserved for Future Use ²	16
V_{CC}	AMB Core Power and AMB Channel Interface Power (1.5 Volt)	8
V_{DD}	DRAM Power and AMB DRAM I/O Power (1.8 Volt)	24
V_{TT}	DRAM Address/Command/Clock Termination Power ($V_{DD}/2$)	4
V_{DDSPD}	SPD Power	1
V_{SS}	Ground	80
DNU/M_Test	The DNU/M_Test pin provides an external connection on R/Cs A-D for testing the margin of V_{ref} which is produced by a voltage divider on the module. It is not intended to be used in normal system operation and must not be connected (DNU) in a system. This test pin may have other features on future card designs and if it does, will be included in this specification at that time. 1	1
	Total	240

1. System Clock Signals SCK and $\overline{\text{SCK}}$ switch at one half the DRAM CK/ $\overline{\text{CK}}$ frequency
2. Eight pins reserved for forwarded clocks, eight pins reserved for future architecture flexibility

Absolute Maximum Ratings

Symbol	Parameter	MIN	MAX	Units
V_{IN} , V_{OUT}	Voltage on any pin relative to V_{SS}	-0.3	1.75	V
V_{CC}	Voltage on V_{CC} pin relative to V_{SS}	-0.3	1.75	V
V_{DD}	Voltage V_{DD} pin relative to V_{SS}	-0.5	2.3	V
V_{TT}	Voltage on V_{TT} pin relative to V_{SS}	-0.5	2.3	V
T_{STG}	Storage temperature	-55	100	°C
T_{CASE}	DDR2 SDRAM device operating temperature (Ambient)	0	95 ⁽¹⁾	°C
	AMB device operating temperature (Ambient)	0	110	°C

Note: (1) Above 85°C DRAM case temperature the Auto-Refresh command interval has to be reduced to $t_{REFI} = 3.9 \mu\text{s}$.

Continued >>

Functional Block Diagram:

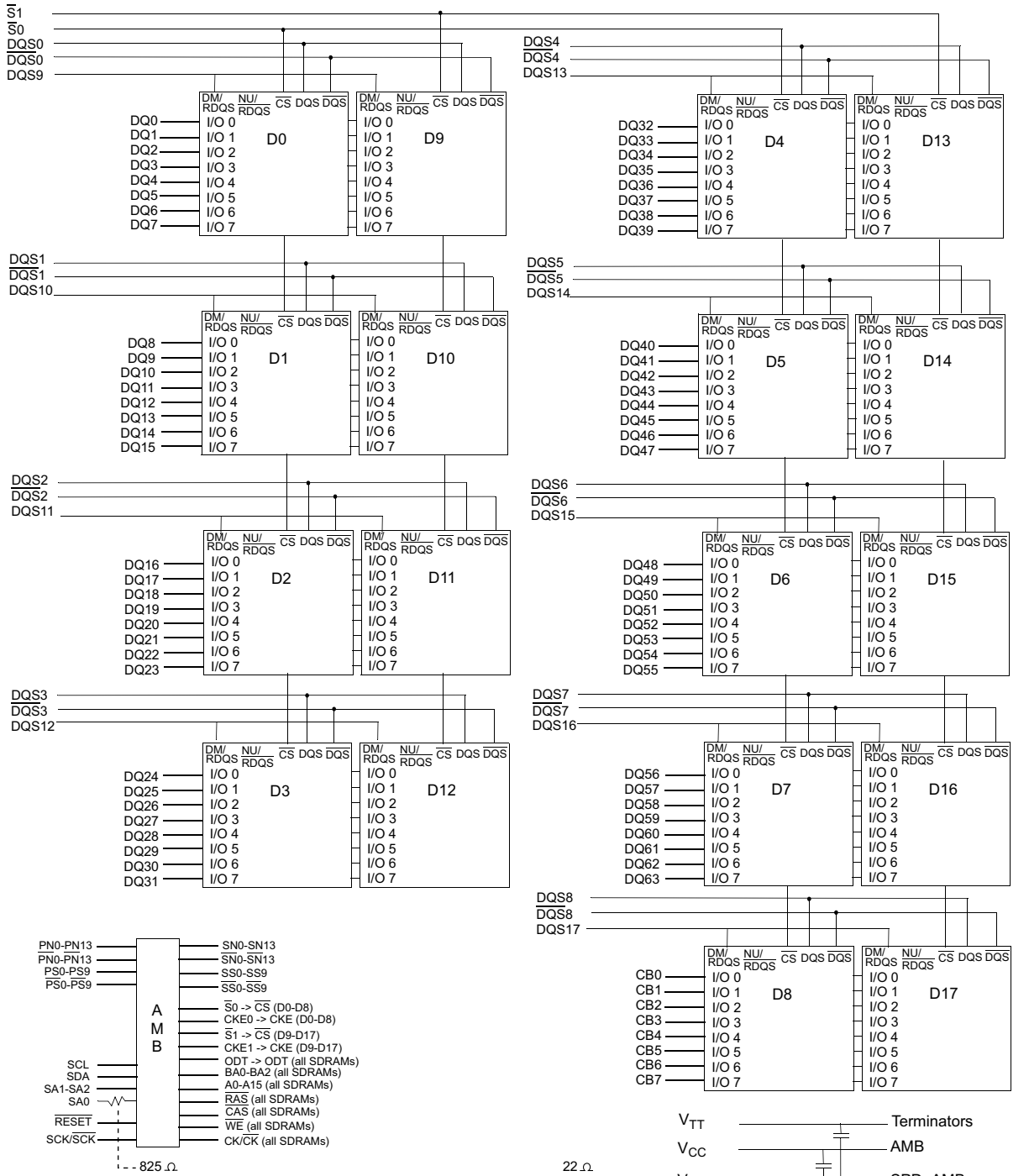

Notes:

1. DQ-to-I/O wiring may be changed within a byte.
2. There are two physical copies of each address/command/control/clock

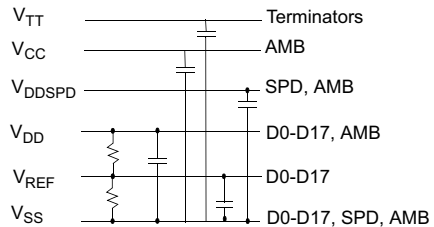
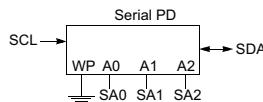

Continued >>

Architecture:**Advanced Memory Buffer Pin Description:**

Pin Name	Pin Description	Count
FB-DIMM Channel Signals		99
SCK	System Clock Input, positive line	1
$\overline{\text{SCK}}$	System Clock Input, negative line	1
PN[13:0]	Primary Northbound Data, positive lines	14
$\overline{\text{PN}}[13:0]$	Primary Northbound Data, negative lines	14
PS[9:0]	Primary Southbound Data, positive lines	10
$\overline{\text{PS}}[9:0]$	Primary Southbound Data, negative lines	10
SN[13:0]	Secondary Northbound Data, positive lines	14
$\overline{\text{SN}}[13:0]$	Secondary Northbound Data, negative lines	14
SS[9:0]	Secondary Southbound Data, positive lines	10
$\overline{\text{SS}}[9:0]$	Secondary Southbound Data, negative lines	10
FBDRES	To an external precision calibration resistor connected to Vcc	1
DDR2 Interface Signals		175
DQS[8:0]	Data Strobes, positive lines	9
$\overline{\text{DQS}}[8:0]$	Data Strobes, negative lines	9
DQS[17:9]/DM[8:0]	Data Strobes (x4 DRAM only), positive lines. These signals are driven low to x8 DRAM on writes.	9
$\overline{\text{DQS}}[17:9]$	Data Strobes (x4 DRAM only), negative lines	9
DQ[63:0]	Data	64
CB[7:0]	Checkbits	8
A[15:0]A, A[15:0]B	Addresses. A10 is part of the pre-charge command	32
BA[2:0]A, BA[2:0]B	Bank Addresses	6
$\overline{\text{RASA}}$, $\overline{\text{RASB}}$	Part of command, with $\overline{\text{CAS}}$, $\overline{\text{WE}}$, and $\overline{\text{CS}}[1:0]$.	2
$\overline{\text{CASA}}$, $\overline{\text{CASB}}$	Part of command, with $\overline{\text{RAS}}$, $\overline{\text{WE}}$, and $\overline{\text{CS}}[1:0]$.	2
$\overline{\text{WEA}}$, $\overline{\text{WEB}}$	Part of command, with $\overline{\text{RAS}}$, $\overline{\text{CAS}}$, and $\overline{\text{CS}}[1:0]$.	2
ODTA, ODTB	On-die Termination Enable	2
CKE[1:0]A, CKE[1:0]B	Clock Enable (one per rank)	4
$\overline{\text{CS}}[1:0]A$, $\overline{\text{CS}}[1:0]B$	Chip Select (one per rank)	4
CLK[3:0]	CLK[1:0] used on 9 and 18 device DIMMs, CLK[3:0] used on 36 device DIMMs. CLK[3:2] should be output disabled when not in use.	4
$\overline{\text{CLK}}[3:0]$	Negative lines for CLK[3:0]	4
DDRC_C14	DDR Compensation: Common return pin for DDRC_B18 and DDRC_C18.	1
DDRC_B18	DDR Compensation: Resistor connected to common return pin DDRC_C14	1
DDRC_C18	DDR Compensation: Resistor connected to common return pin DDRC_C14	1
DDRC_B12	DDR Compensation: Resistor connected to V _{SS}	1
DDRC_C12	DDR Compensation: Resistor connected to V _{DD}	1

Continued >>

Advanced Memory Buffer Pin Description:

SPD Bus Interface Signals		5
SCL	Serial Presence Detect (SPD) Clock Input	1
SDA	SPD Data Input / Output	1
SA[2:0]	SPD Address Inputs, also used to select the DIMM number in the AMB	3
Miscellaneous Signals		163
PLLSTOP	LL Clock Observability Output	1
VCCAPLL	Analog VCC for the PLL. Tied with low pass filter to VCC.	1
VSSAPLLA	analog VSS for the PLL. Tied to ground on the AMB die. Do not tie to ground on the DIMM.1	
TEST_pin#	Leave floating on the DIMM	6
TESTLO_pin#	Tie to ground on the DIMM ²	5
BFUNC	Tie to ground to set functionality as "buffer on DIMM."	1
$\overline{\text{RESET}}$	AMB reset signal	1
NC	No connect. Many NC are connected to VDD on the DIMM, to lower the impedance of the VDD power islands.	129
RFUR	Reserved for Future Use	18
Power/Ground Signals		213
V _{CC}	AMB Core Power (1.5 Volt)	24
V _{CCFBD}	AMB Channel I/O Power (1.5 Volt)	8
V _{DD}	AMB DRAM I/O Power (1.8 Volt)	24
V _{DDSPD}	SPD Power (3.3 Volt)	1
V _{SS}	Ground	156
Total		655
<p>1. System Clock Signals SCK and $\overline{\text{SCK}}$ switch at one half the DRAM CK/$\overline{\text{CK}}$ frequency.</p> <p>2. TESTLO_AB20 and TESTLO_AC20 should be configured for debug purposes on prototype DIMMs: each pin should have a zero ohm resistor pulldown to ground, and an unpopulated resistor pullup to VCC. These resistors can be replaced on production DIMMs with a direct connection to ground.</p>		

Continued >>

Package Dimensions:

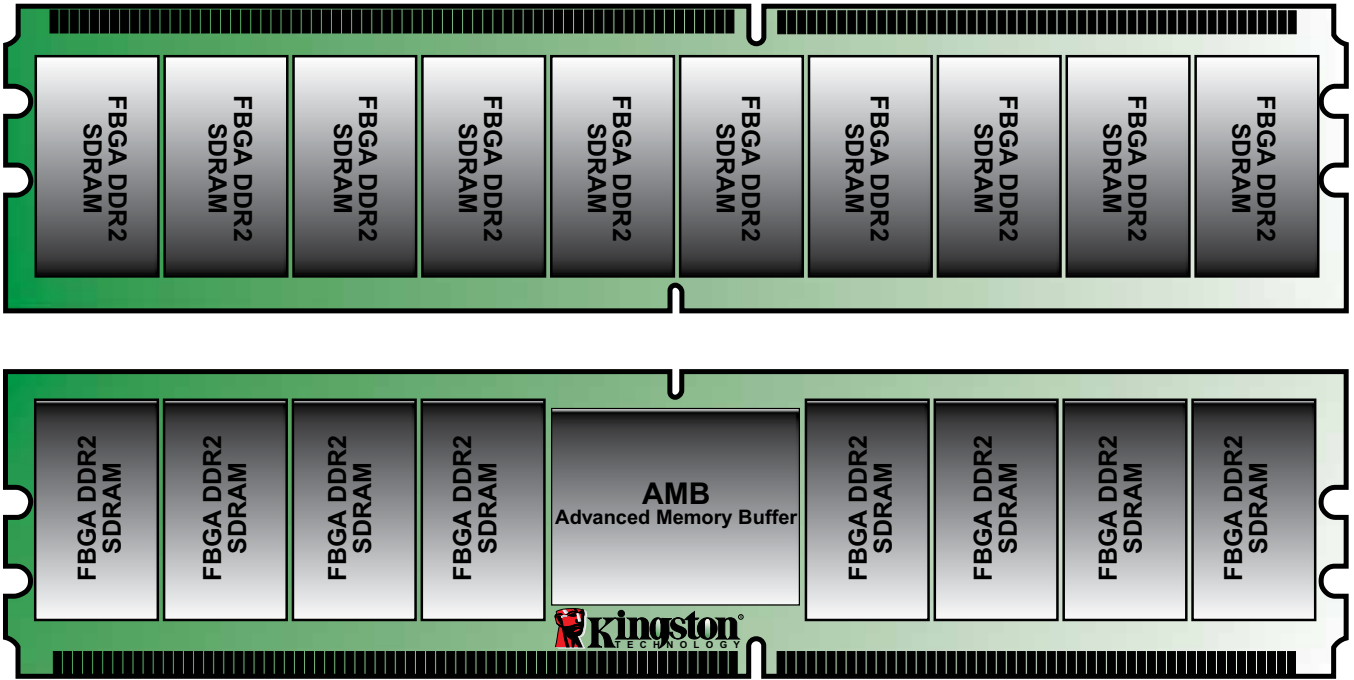

(Units = millimeters)

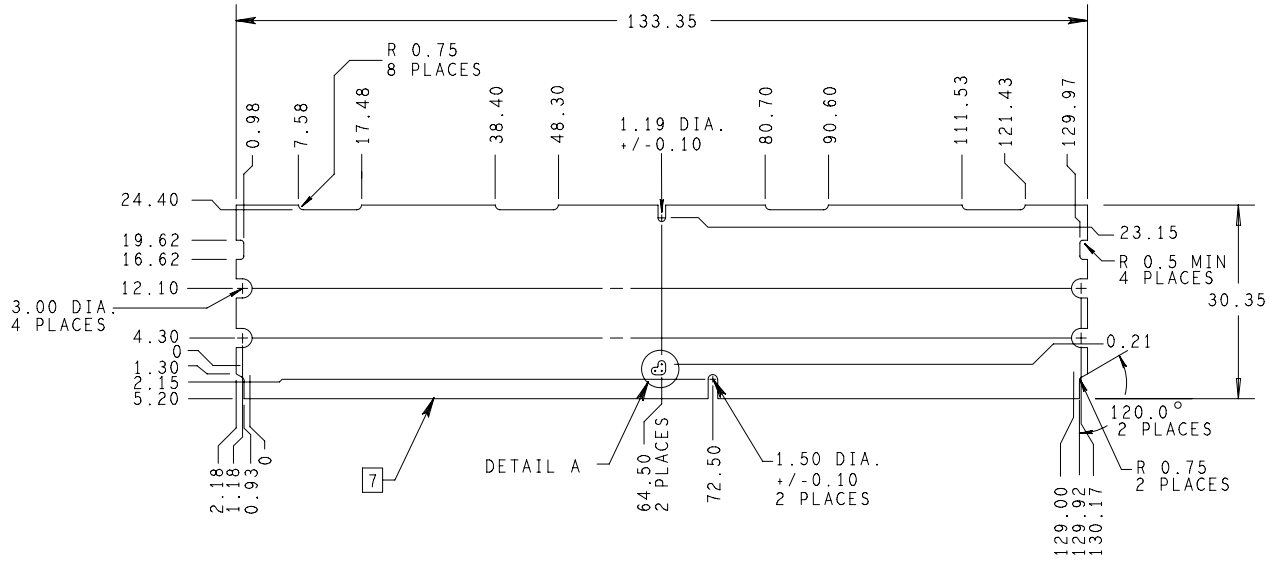

0.346 (8.8)
MAX with heat sink

Units: inches (millimeters)

